

The Creo® Suite of NC and Tooling Solutions

WHAT YOU NEED TO CAPITALIZE ON GLOBAL MANUFACTURING EXCELLENCE

To gain a competitive edge in product development, companies are increasingly leveraging globally distributed design teams and offshore manufacturing facilities. In this environment, enabling a smooth transition from product design to manufacturing is critical in order to achieve manufacturing excellence and successful product development. For machine shops both large and small, opportunities abound – that is, for those organizations with the tools and skills top manufacturers now demand.

With Creo manufacturing tools for CAD/CAM, you have exactly what you need to win new business opportunities and lock out the competition. Easy to use, with unmatched power and performance, Creo NC and Tooling solutions are the world standard – providing you with everything you need to achieve the highest quality, highest precision machining in the fastest possible time. Our complete family of applications can handle every aspect of the machine process, from mold design and advanced NC to 3D CAD simulation and verification.

Creo machining solutions work alongside Creo, giving you true concurrent design through manufacture. So you have the confidence knowing your parts are cut efficiently and accurately.

Put yourself in the best possible position to win new business, now emerging all across the globe by installing Creo NC and Tooling solutions today.

The Complete Set of CAD Solutions –On a Single, Integrated Platform

The Creo family of CAD/CAM/CAE software applications delivers a distinct advantage because every tool is fully 'associative': any change made to the

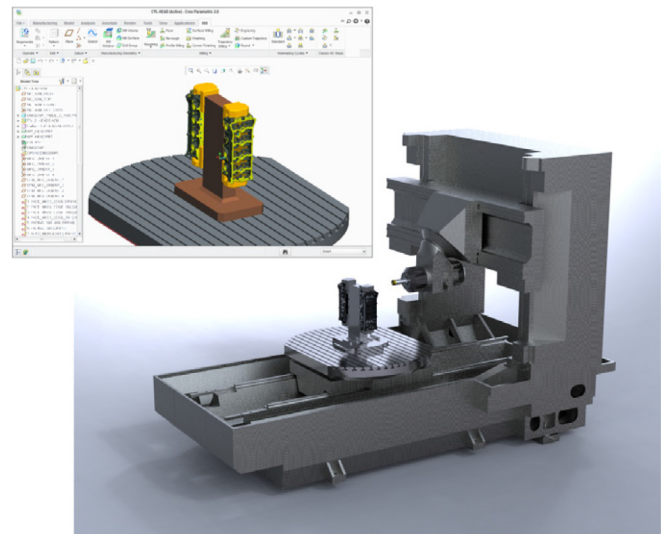

Enable digital manufacturing with Creo suite of NC and Tooling extensions.

design is automatically reflected in all downstream deliverables –without any translation of model information between applications. By eliminating data translation, you not only save time, but you also avoid potential errors in your design. No other 3D package offers such a complete set of native manufacturing applications – from tool and die design, to NC programming, process documentation,

post-processing, and toolpath verification and simulation. Concurrent design and manufacturing is available only in Creo.

Creo CAM Solutions

Creo Prismatic and Multi-Surface Milling Extension

Easy-to-use, feature-rich, and seamlessly integrated with design—Creo Prismatic and Multi-Surface Milling is a virtual milling ‘specialist’ for prismatic production machining.

- Multi-surface 3-axis milling, with support for high-speed machining
- 4-axis and 5-axis positioning
- NC-program creation, process documentation, post-processing, and toolpath verification/simulation
- Improves product quality and manufacturing consistency by generating toolpaths directly on solid models
- Part of an integral CAD/CAM solution—no data translation required
- Reduces time-to-market via associative toolpath updates to design changes

Creo Production Machining Extension

In addition to robust NC programming capabilities spanning the functions of milling, turning, and wire EDM, Creo Production Machining also offers seamless compatibility with design, which means that changes are automatically incorporated. The result: improved time-to-production and customer responsiveness.

- Includes all the capabilities of Creo Prismatic and Multi-Surface Milling Extension
- Supports CNC mills, 2-axis and 4-axis CNC lathes, and 2-axis and 4-axis CNC wire EDM machines
- Provides low-level NC sequence editing, allowing precise toolpath control and optimization

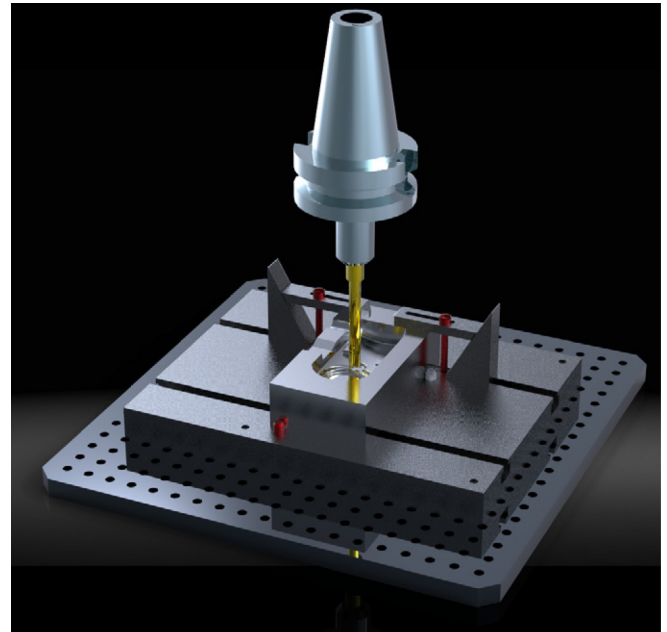

Powerful High Speed Machining toolpaths for core and cavity manufacturing.

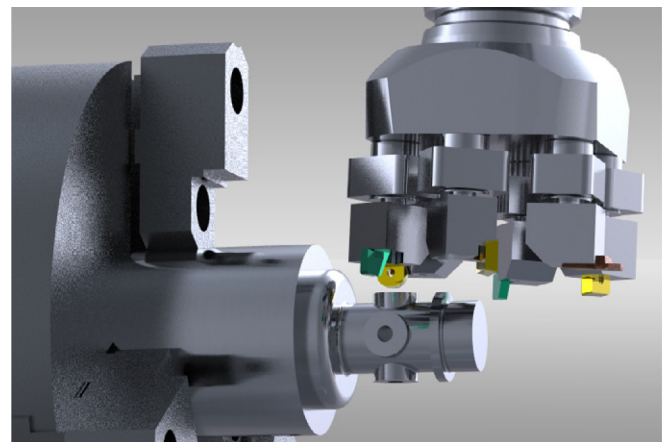

Turning in Creo Production Machining.

- Detailed step-by-step production planning instructions improve manufacturing efficiency and reduce development cost
- Optimized NC programming for families of designs accelerates time-to-volume production

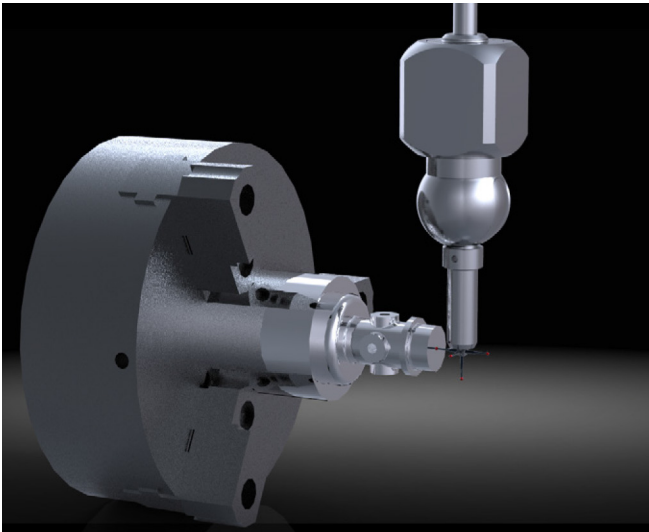

For production machining applications, Creo complete machining improves manufacturing set-up and quality control processes with in-process probing support.

Creo Complete Machining Extension

Enjoy all the capabilities of Creo Production Machining, along with multi-axis machining, plus full NC programming and extensive tool libraries. Now you can drive any type of CNC machine, including 2.5- to 5-axis mills, 2- to 4-axis lathes (synchronized or not), multi-axis mill/turn, and 2- to 4-axis wire EDM.

- 2.5- to 5-axis milling, multi-axis turning and mill/turn (live tooling); 4-axis wire EDM
- Simplifies storage and reuse of best practices by using proven manufacturing templates
- Improves product quality and manufacturing consistency by generating toolpaths directly on 3D designs
- Reduces time-to-market via associative tool-path updates to design changes
- Part of an integral CAD/CAM solution—no data translation required
- Improves manufacturing set-up and quality control processes with in-process probing support
- Provides robust data management of manufacturing models and deliverables with Windchill® PDMLink® and Windchill MPMLink™ (optionally available)

Tools for Adapting & Winning in Today's Competitive Market

Creo Tool Design

Create the most complex single-cavity and multi-cavity molds and casts with ease. Evaluate mold draft, undercut and thickness problems, and then automatically create parting surface and splitting geometry in a process-driven environment that's simple—even for the occasional user—who needs to create complex tooling quickly.

- Define even the most complex geometry for creating single- and multiple-cavity molds and casts
- Evaluate mold draft, undercut and thickness problems and examine forming and secondary forming dies
- Eliminate data translation errors using an integral CAD/CAM solution from conceptual design to manufacturing
- Reduce the need for redesigns through automatic updating of tooling models, drawings and electrodes
- Eliminate costly rework via interference checking and mold opening simulation

Creo Expert Moldbase Extension

Work in a familiar 2D environment for moldbase layout—and get all the benefits of 3D! The 2D process-driven GUI offers a catalog of standard and custom components, and updates your model automatically during the development of the moldbase, by providing a catalog of standard and customized components. Your resulting 3D models are then used for interference checking during mold opening, as well as automatic generation of deliverables such as detail drawings and BOMs.

- Speeds the design process through a simple, process-driven workflow that automates moldbase design and detailing

- Provides an ever growing set of libraries (currently 17) for moldbase/component suppliers (includes screws, ejector pins, sliders, cooling fittings, etc.). Easily add custom data for unique items
- Automatic ejector pin, waterline, and fittings functions; automated runners and waterline checks
- Prevents costly rework and reduces cycle time by eliminating mistakes via a 3D environment
- Reduces the need for redesigns by automatically updating tooling models, drawings and electrodes

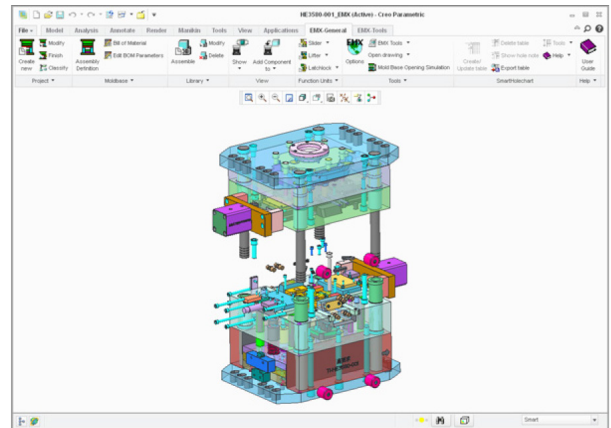

An exploded moldbase in Creo Expert Moldbase Extension.

	Prismatic & Multi-Surface Milling	Production Machining	Complete Machining	Tool Design	Expert Moldbase	Progressive Die	NC Sheetmetal	Computer-Aided Verification
2-Axis Feature-based Machining	•	•	•					
3-Axis Milling	•	•	•					
4/5-Axis Positioning Milling	•	•	•					
4-Axis Turning		•	•					
4-Axis Wire EDM		•	•					
Live Tooling for Turning (Mill/Turn: CBY)			•					
5-Axis Continuous Milling and Contouring Machines			•					
Extraction of Manufacturing Annotation Features	•	•	•					
Tool and Fixture Library	•	•	•					
Manufacturing Process Documentation Pro/PROCESS for Manufacturing	•	•	•					
Automatic Nesting							•	
Punch Press and 2-Axis Laser Programming							•	
GPOST: NC Post-Processor Generator	•	•	•				•	
VERICUT for Creo: NC Simulation	•	•	•					
Automatic Core/Cavity creation				•				
Moldbase Design, including Moldbase Component Library				○	•			
Progressive Die Design						•		
First Article Inspection (compare 3D model with cloud of points)								•
CMM Programming (DMIS output)								•

All of the options above require a seat of Creo Parametric.

• Capability included ○ Basic moldbase layout functionality

A Solution for Your Role in Manufacturing

No matter what role you perform in product manufacturing, Creo has a precision CAM tool that can help you deliver higher-quality products—at a lower cost—in the shortest time frame possible. Here are additional CAM tools that are helping engineers in a variety of manufacturing disciplines:

Creo Progressive Die Extension

Easy-to-use wizards guide you through automatic strip layout definition, cut stamp creation, and placement/modification of die components. You can eliminate error-prone manual tasks by automatically creating clearance cuts, drilled holes, and documentation.

Creo NC Sheetmetal Extension

Boost productivity by automatically creating and optimizing toolpaths using standard and form tools. Use auto-nesting to maximize your sheet area, thus reducing scrap and material costs and cutting lead times.

Creo Computer-Aided Verification Extension

Gain absolute confidence in the QA process by performing digital inspections of machined parts and assemblies. The exactness of a digital-quality checking process saves time, effort and money.

Creo Plastic Advisor Extension

By simulating the plastic-filling process for injection-molded parts, you can design-for-manufacturability, uncover problems, and propose remedies, thus reducing development time and expense.

For the most up-to-date platform support information, please visit: PTC.com/products/creo

© 2013, PTC. All rights reserved. Information described herein is furnished for informational use only, is subject to change without notice, and should not be construed as a guarantee, commitment, condition or offer by PTC. PTC, the PTC Logo, PTC Arbortext, PTC Arbortext IsoDraw, PTC Arbortext IsoView, PTC Pro/ENGINEER, PTC ProductView, PTC Windchill, PTC Windchill PDMLink, and all PTC product names and logos are trademarks or registered trademarks of PTC and/or its subsidiaries in the United States and in other countries. All other product or company names are property of their respective owners. The timing of any product release, including any features or functionality, is subject to change at PTC's discretion.

J2568-PTC-Creo-NC-Tooling-DS-EN-0813